

THIS DOCUMENT CONTAINS PROPRIETARY INFORMATION AND EXCEPT WITH WRITTEN PERMISSION OF TRI-STAR ELECTRONICS INT'L, INC. SUCH INFORMATION SHALL NOT BE REPRODUCED, COPIED, DISCLOSED TO OTHERS, OR USED FOR ANY PURPOSES. THIS DOCUMENT SHALL NOT BE DUPLICATED IN WHOLE OR IN PART.

C		REVISED PER EO 14254		2-22-01		FMA	
---	--	----------------------	--	---------	--	-----	--

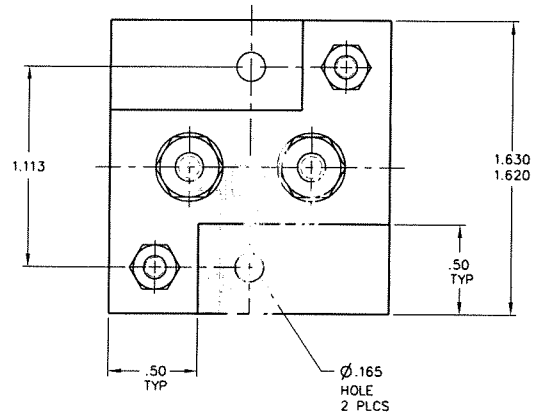
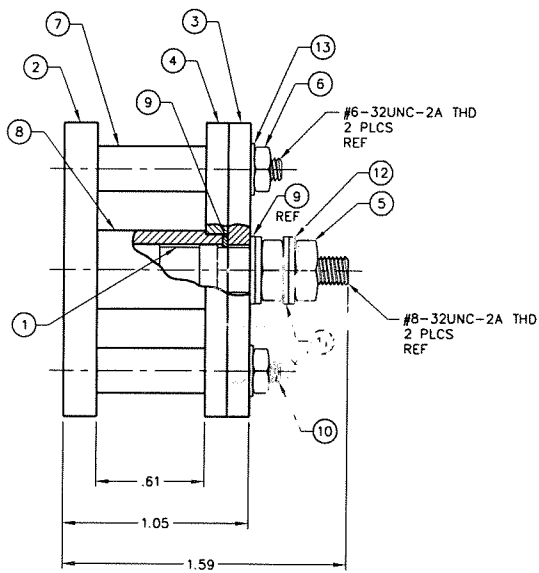
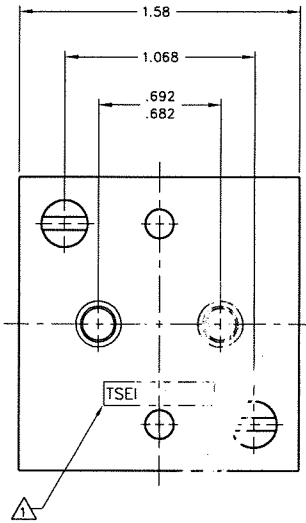

2		LOCKWASHER, #6-32		13
4		LOCKWASHER, #8-32	STEEL/CADMIUM PLATED	12
2		WASHER, #8-32		11
2		SCREW, #6-32 X 1.250L		10
4		WASHER, KEYING	STAINLESS STEEL/PASSIVATED	9
2		BUSHING		8
2		SPACER		7
2		NUT, #6-32	BRASS	6
4		NUT, #8-32		5
1		PLATE, TOP, INNER		4
1		PLATE, TOP	OS GLASS MELAMINE	3
1		PLATE, BASE		2
2		CONTACT, SOCKET, SIZE 5	COPPER ALLOY	1

△ PART MARKING: TSEI, DATE CODE, CAGE CODE "55104" AND PART NUMBER.

NOTES (UNLESS OTHERWISE SPECIFIED)

UNLESS OTHERWISE SPECIFIED, DIMENSIONS ARE IN INCHES. TOLERANCES ARE: ANGLES ±30°    .01" ±.005"    .001" ±.001"		<b>TRI-STAR ELECTRONICS INT'L, INC.</b> 2201 ROSECRANS AVE., EL SEQUOIA, CA 90245	
APPROVALS J. OULTANGON 10/3/91 M. L. LEONOR 10/3/91 L.B. ODUCA 10/3/91 F.M. ACOSTA JR 10/3/91		DATE 10/3/91 10/3/91 10/3/91 10/3/91	
PART NO. 55104 CAGE CODE 55104 SCALE NONE		PART NO. CBC-13303 CAGE CODE CBC1333	