

REVISIONS			
REV.	DESCRIPTION	DATE	APPROVED
-	INITIAL RELEASE	07/03/2018	MM
1	UPDATED PART NUMBER	10/24/2018	DL
2	ADDED SHEET 2 PCB DEFINITION	2/19/2019	PV
3	CORRECTED PCB POST HOLE DIA	4/29/2019	PV
4	UPD PCB (COMMON SL AND CPW)	5/13/2019	PV
5	CHANGED PN, WAS: TMB-V5FS-2SM	1/9/2020	PV

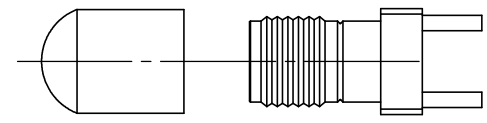
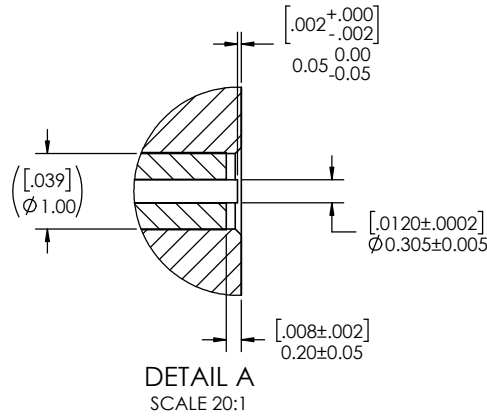
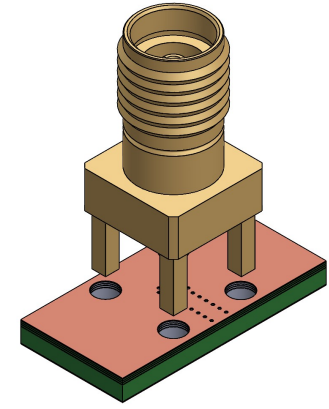
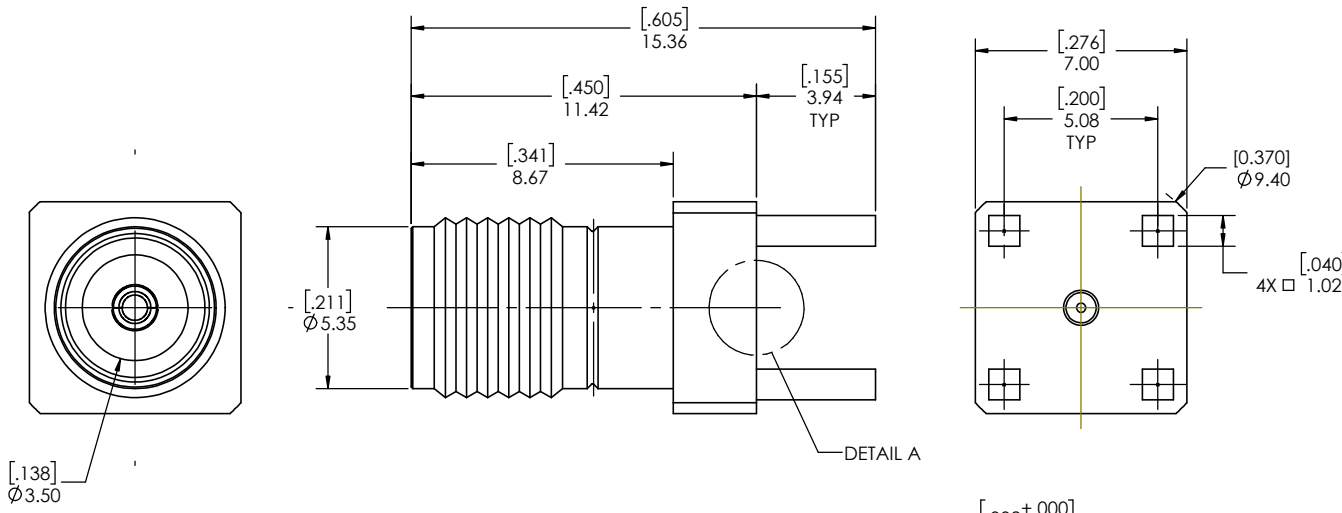

PROTECTION CAP

- NOTE(S):
1. These characteristics are typical and for reference.
 2. See sheet 2 for PCB interface definition.
 3. For questions please contact sales@amphenolcdi.com

MATERIAL(S):	ELECTRICAL(S):	MECHANICAL(S):	ENVIRONMENTAL(S):
Body: Brass Center Conductor: Beryllium Copper Insulator: Insulator 1: PCTFE, white Insulator 2: PTFE, white RoHS Compliant Protective Cap: Soft PVC Color: White	Impedence: 50 Ohms Nominal Frequency Range: DC to 34 GHz VSWR: 1.3:1 max at 34 GHz Working Voltage: 400 Vrms max @ Sea Level Dielectric Withstand Voltage: 500 Vrms max. Insulation Resistance: 5000 Megaohms min. Contact Resistance: Initial: Center Contact: 1.5 Milliohms max Outer Contact: 0.8 Milliohms max	Mating Characteristics: Interface per MIL-STD-348 Force to Engage & Disengage: Torque: 2 inch-pounds max Longitudinal Force: NA Connector Durability: 500 Cycles min. Permeability: Less than 2.0 mu. Center Contact Retention: Axial Force: 6 pounds min. Radial Force: NA	Temperature Range: -65°C to +165°C Moisture Resistance: MIL-STD-202, Method 103, Test Condition B Corrosion: MIL-STD-202, Method 101, Test Condition B Vibration: MIL-STD-202, Method 204, Test Condition A Shock: MIL-STD-202, Method 213, Test Condition I

FINISH(ES): Body: Gold Plating Center Conductor: Gold Plating	DIMENSIONS ARE IN MILLIMETERS [INCHES] ± TOLERANCES UNLESS OTHERWISE NOTED				THIRD ANGLE PROJECTION 	
	.X 0.3mm [.012"]	.XX 0.15mm [.006"]	.XXX 0.050mm [.002"]	.XXXX 0.010mm [.0004"]		
THE INFORMATION CONTAINED HEREIN IS PROPRIETARY TO AMPHENOL, AND SHALL IN NO WAY BE REPRODUCED OR DISCLOSED IN WHOLE OR IN PART OR USED FOR ANY DESIGN OR MANUFACTURE EXCEPT WHEN SUCH USER POSSESSES DIRECT, WRITTEN AUTHORIZATION FROM AMPHENOL.				NEXT ASSY. USED ON APPLICATION		SCALE: 8:1 DO NOT SCALE DRAWING



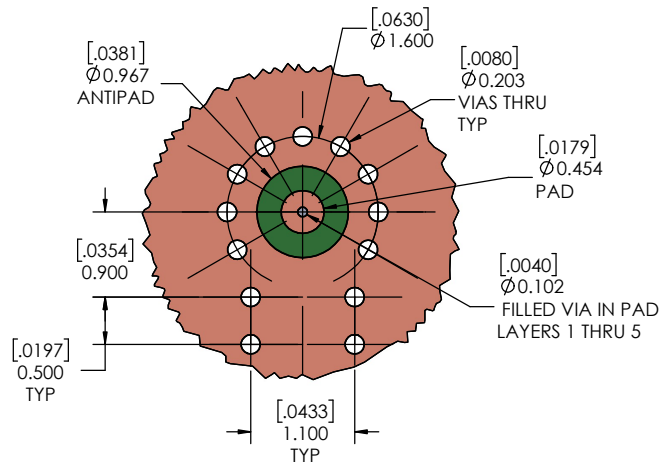

DETAIL B
SCALE 25:1
LAYER 1 (Cu)

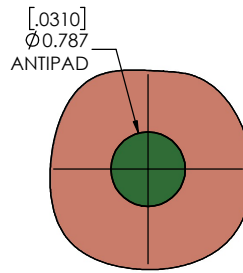

DETAIL B
SCALE 25:1
LAYER 3 (Cu)
VIAS NOT SHOWN FOR CLARITY

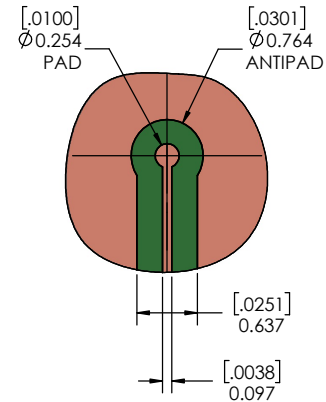

DETAIL B
SCALE 25:1
LAYER 5 (Cu)
VIAS NOT SHOWN FOR CLARITY

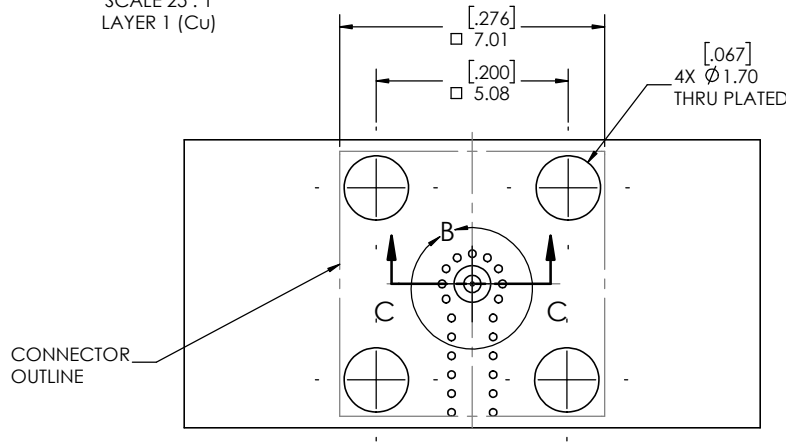

CONNECTOR
OUTLINE

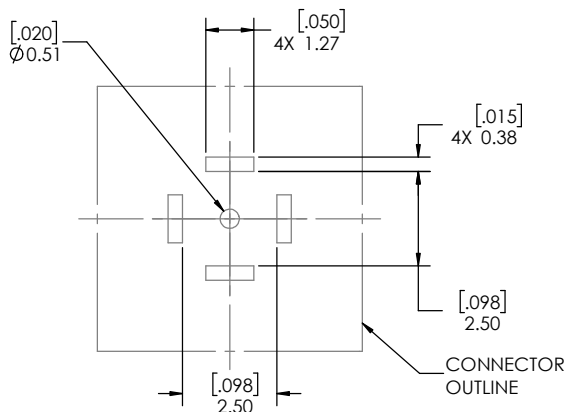

SOLDER PASTE STENCIL
SCALE 10:1

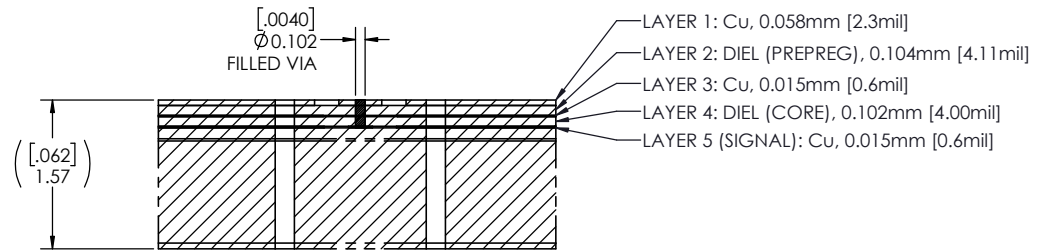

SECTION C-C
SCALE 25:1
PCB LAYER DEFINITION

PCB LAYOUT
(FOR REFERENCE ONLY)



3.50mm STRAIGHT JACK,
VERTICAL SOLDER (SIGNAL
PAD)

SIZE	CAGE CODE	PART NUMBER	REV
C	7M294	TMB-V5FS-3SM	5
SCALE: 10:1		PART NUMBER: TMB-V5FS-3SM 2 OF 2	