

4

3

2

1

PART NO.	CAPTIVATION METHOD
BASIC	NONE
SF	NONE
CC	EPOXY ONLY
CCSF	EPOXY ONLY
CCCE	EPOXY WITH CONDUCTIVE
CCCESF	EPOXY WITH CONDUCTIVE

REVISIONS			
REV.	DESCRIPTION	DATE	BY
D	ECO 26011	07.25.12	DKN
E	ECO 27338	10.16.13	DKN
F	ECO 204053 (CHG NAME)	07.01.25	DKN

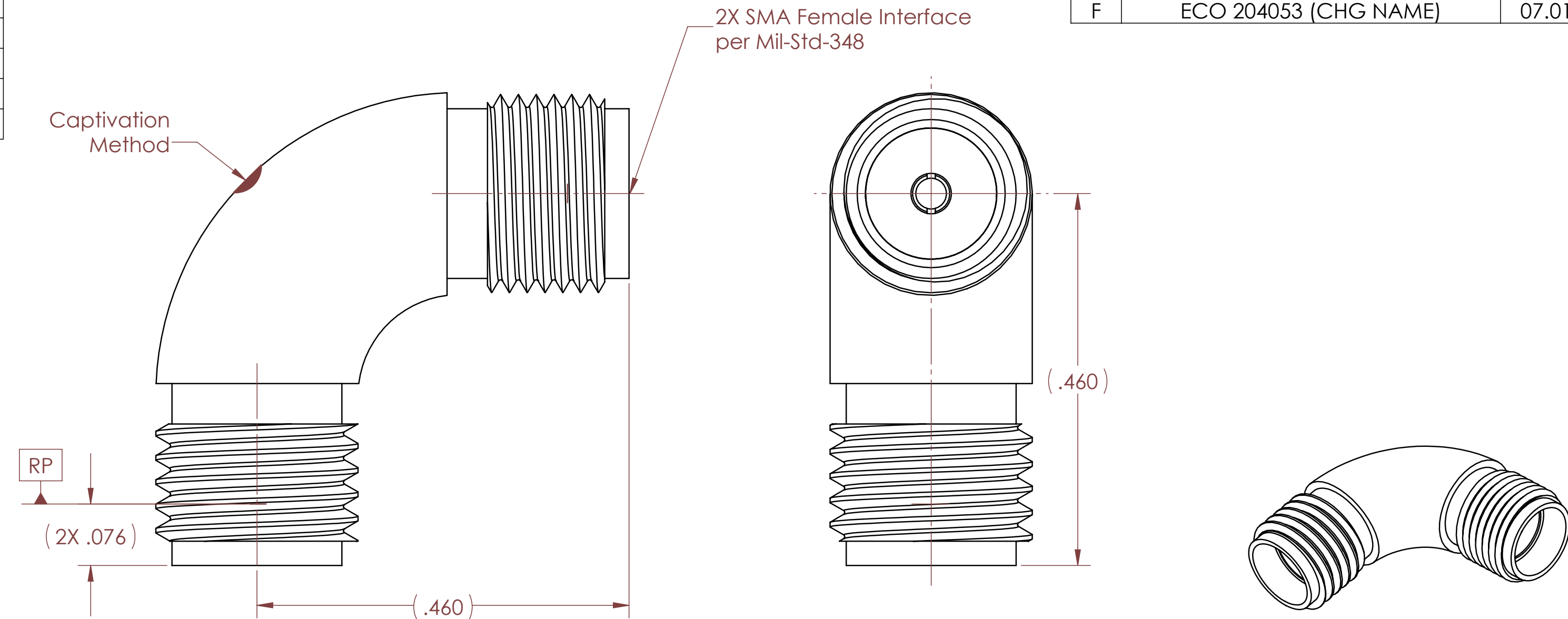

MATERIAL(S):	ELECTRICAL(S):	MECHANICAL(S):	ENVIRONMENTAL(S):
Body: 304 SST per SAE-AMS-5567 Center Conductor: BeCu Alloy per ASTM B196 Dielectric: PTFE Teflon per ASTM D1710 Epoxy: Sigma VF Type HV Conductive Epoxy: Eccobond 56C	Impedance: 50 Ohms Nominal Frequency Range: DC to 18.0 GHz VSWR: 1.25: max @ 18GHz Insertion Loss: .20 dB max @ 18GHz Working Voltage: 335 Vrms max @ Sea Level Dielectric Withstand Voltage: 1,000 Vrms min. RF HiPot Voltage: 670 Vrms min. @ 5MHz Corona Level: 250 Vrms @ 70,000 ft Insulation Resistance: 5,000 MegOhms min. RF Leakage: -(65 - fGHz) dB (For CC & CCSF). RF Leakage: -(90 - fGHz) dB (For BASIC & SF). Contact Resistance: Before Environment: Center Contact: 3.0 Milliohms max Outer Contact: 2.0 Milliohms max After Environment: Center Contact: 4.0 Milliohms max Outer Contact: NA	Mating Characteristics: Interface per MIL-STD-348 Force to Engage & Disengage: Torque: 2 inch-lbs max Longitudinal Force: NA Connector Durability: 500 Cycles min. @ 12 cycles/minute max Permeability: Less than 2.0 mu. Center Contact Retention: ** Axial Force: 6 lbs min.  ** Not applicable to P/N 5065 and 5065SF	Temperature Range: For BASIC & SF: -65°C to +165°C For CC, CCSF, CCCE & CCCESF: -65°C to +125°C Thermal Shock: MIL-STD-202, Method 107, Test Condition B Moisture Resistance: MIL-STD-202, Method 106, Insulation resistance at least 200 MegOhms within 5 minutes after removal from humidity. Corrosion: MIL-STD-202, Method 101, Test Condition B Vibration: MIL-STD-202, Method 204, Test Condition D Shock: MIL-STD-202, Method 213, Test Condition I

FINISH(ES):	APPLICABLE Amphenol CDI DOCUMENTS	TOLERANCES AND NOTES	MATERIAL	SPECIFICATION	PROCUREMENT																														
Body: For SF & CCSF: Passivate per ASTM A967 or SAE AMS 2700. For BASIC & CCSF: Gold plate per ASTM B488, Type II, Code C, Class .25, over Nickel plate per SAE AMS-QQ-N-290, Class 1. Center Conductor: Gold plate per ASTM B488, Type II, Code C or D, Class 1.25, over Nickel plate per SAE AMS-QQ-N-290, Class 1.	<table border="1"> <thead> <tr> <th>WORK STANDARD</th> <th>PROD INSTRUC</th> <th>ASSY INSTRUC</th> </tr> </thead> <tbody> <tr> <td>NA</td> <td>NA</td> <td>NA</td> </tr> </tbody> </table>	WORK STANDARD	PROD INSTRUC	ASSY INSTRUC	NA	NA	NA	EXCEPT AS NOTED DIMENSIONS ARE IN INCHES. .XX ±.015 ANGULAR ± 1/2° LINEAR .XXX ±.005 FRACTION ± 1/32 INTERPRET DRAWING PER ASME Y14.5 - 2018 1. MACHINE FINISH: 63/ RMS 2. BREAK ALL SHARP EDGES .003 MAX. 3. MACHINED FILLETS .005 MAX. 4. MACHINED SURFACES SQUARE TO RESPECTIVE AXIS WITHIN .005 INCHES PER INCH. 5. MACHINED DIAMETERS CONCENTRIC WITHIN .002 T.I.R. 6. DIMENSIONS TO BE MET AFTER PLATING. 7. CHAMFER ALL THREADS 45°. 8. THREADS PER H-28 9. REMOVE FRAYED EDGES ON TEFLON. 10. REMOVE ALL BURRS.	<table border="1"> <thead> <tr> <th>APPROVAL</th> <th>INITIALS</th> <th>DATE</th> </tr> </thead> <tbody> <tr> <td>DRAWN BY</td> <td>JF</td> <td>11.12.04</td> </tr> <tr> <td>CHECKED BY</td> <td>-</td> <td>-</td> </tr> <tr> <td>TEST ENGR</td> <td>-</td> <td>-</td> </tr> <tr> <td>QUALITY</td> <td>-</td> <td>-</td> </tr> <tr> <td>DESIGN ENG</td> <td>P.MAO</td> <td>10.02.09</td> </tr> <tr> <td>MFG. ENGR</td> <td>-</td> <td>-</td> </tr> <tr> <td>ECO APPRV</td> <td>Dng</td> <td>07.09.25</td> </tr> </tbody> </table>	APPROVAL	INITIALS	DATE	DRAWN BY	JF	11.12.04	CHECKED BY	-	-	TEST ENGR	-	-	QUALITY	-	-	DESIGN ENG	P.MAO	10.02.09	MFG. ENGR	-	-	ECO APPRV	Dng	07.09.25	TITLE <b>SMA MALE TO SMA MALE RADIUS R/A, ADAPTER</b> SCALE: 8:1 SUB-DIRECTORY/OUTLINE\	12900 Alondra Blvd. Cerritos, CA 90703 SHEET 1 OF 1 DRAWING NO. OL_5095 REV. F
WORK STANDARD	PROD INSTRUC	ASSY INSTRUC																																	
NA	NA	NA																																	
APPROVAL	INITIALS	DATE																																	
DRAWN BY	JF	11.12.04																																	
CHECKED BY	-	-																																	
TEST ENGR	-	-																																	
QUALITY	-	-																																	
DESIGN ENG	P.MAO	10.02.09																																	
MFG. ENGR	-	-																																	
ECO APPRV	Dng	07.09.25																																	

4

3

2

1