

4

3

2

1

REVISIONS			
REV.	DESCRIPTION	DATE	APPROVED
x1	OL	07/21/25	K.LE

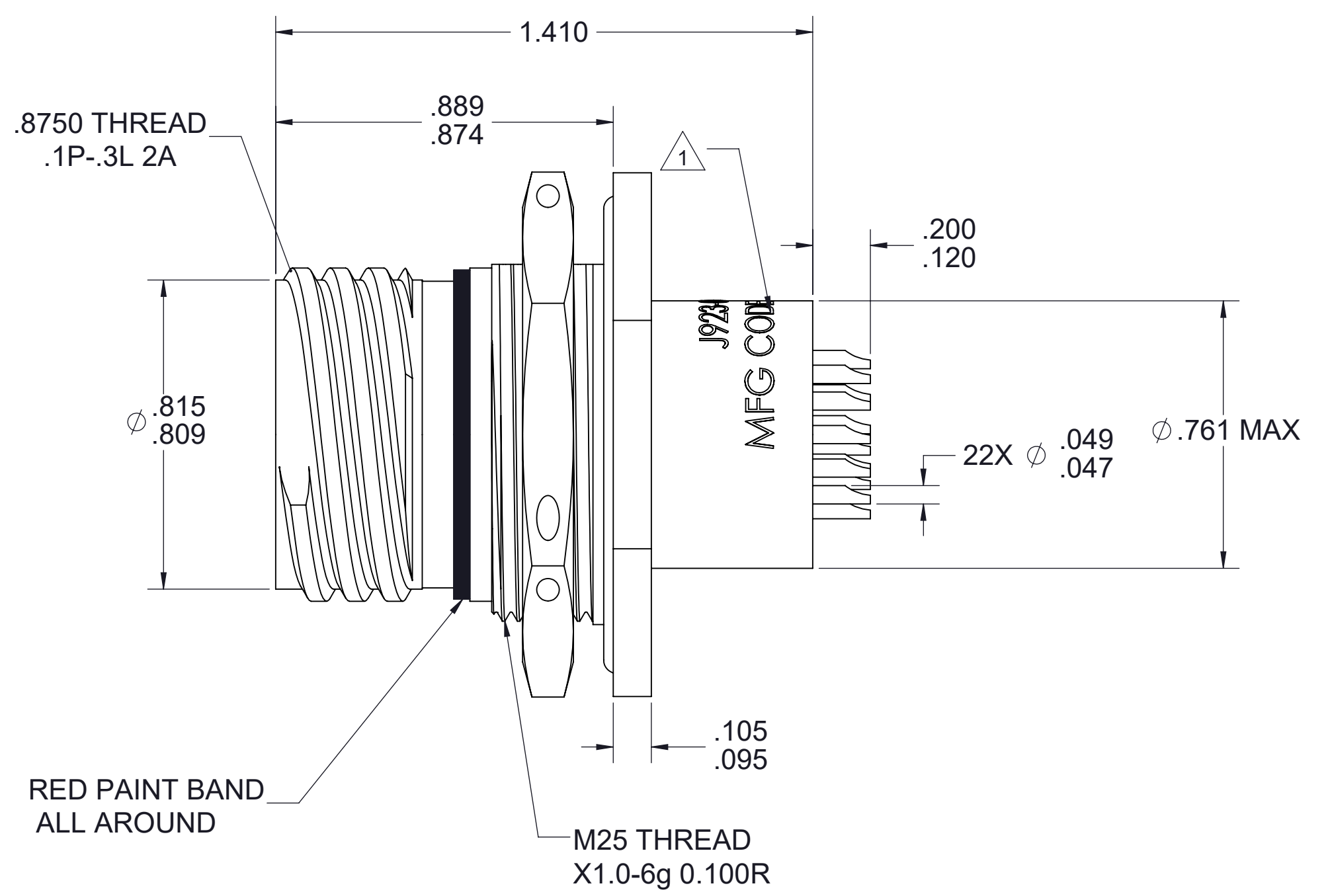
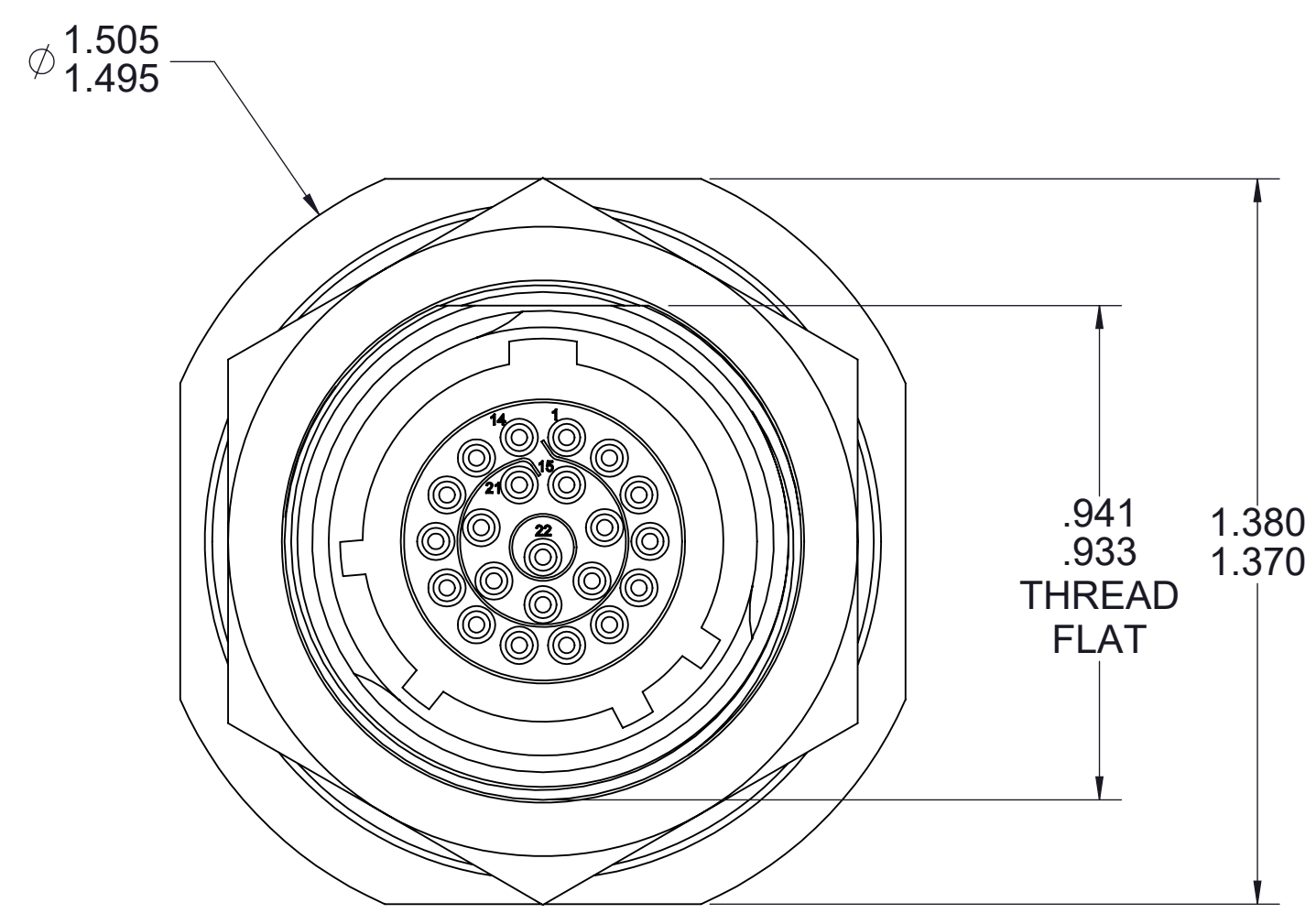

**MATERIAL AND FINISH:**  
 SHELL: ALUMINUM ALLOY 6061-T6.  
 FINISH: ELECTROLESS NICKEL PLATE.  
 CONTACT: COPPER ALLOY PER SAE-AS39029.  
 FINISH: GOLD PLATED.  
 CAPACITORS: CERAMIC, PLANAR.  
 INSULATOR: EPOXY GLASS LAMINATE PER MIL-DTL-38999.  
 INTERFACIAL SEAL: FLUOROSILICONE PER MIL-DTL-38999.  
 GROUND SPRING: BERYLLIUM COPPER, GOLD PLATED.  
 JAM NUT: ALUMINUM ALLOY, ELECTROLESS NICKEL PLATED.  
 FERRITE: NICKEL ZINC.  
 SOLDER PREFORM: INDIUM SOLDER ALLOY, 90In/10Ag.  
 POTTING: EPOXY 2850FT/CAT9

**ELECTRICAL:**  
 PT FILTER  
 A. CAPACITANCE: 3300-5000 pF  
 B. I.R.: 5000 MEGOHMS MIN AT 500 VDC  
 C. D.W.V: 500 VDC, 2 SEC MIN. DWELL TIME.  
 D. ATTENUATION: PER MIL-STD-220 AT 25°C  
 3 dB MIN. AT 5 MHz  
 9 dB MIN. AT 10 MHz  
 45 dB MIN. AT 100 MHz  
 55 dB MIN. AT 500-1000 MHz

**MECHANICAL:**  
 ALL INTERFACE DIMENSIONS PER MIL-DTL-38999.  
 INSERT ARRANGEMENT 13-35 PER MIL-STD-1560 PIN ENGAGEMENT.  
 MARKING: MARK WITH "J993JSCN35CPAN"  
 MFG CODE DATE CODE  
 IN LOCATION SHOWN

**ENVIRONMENTAL:**  
 TEMPERATURE RANGE: -55°C TO +125°C.  
 ENVIRONMENTAL TESTING PER MIL-DTL-38999 AVAILABLE UPON REQUEST.

**NOTES:**  
 1. THESE CHARACTERISTICS ARE TYPICAL, AND FOR REFERENCE.  
 2. FOR QUESTIONS PLEASE CONTACT SALES@AMPHENOLCDI.COM

THE INFORMATION CONTAINED HEREIN IS PROPRIETARY TO AMPHENOL. AND SHALL IN NO WAY BE REPRODUCED OR DISCLOSED IN WHOLE OR IN PART OR USED FOR ANY DESIGN OR MANUFACTURE EXCEPT WHEN SUCH USER POSSESSES DIRECT, WRITTEN AUTHORIZATION FROM AMPHENOL.

DIMENSIONS ARE IN INCHES ± TOLERANCES UNLESS OTHERWISE NOTED		-		-		-	
.XX ± 0.005"	ANGULAR	<b>MATERIAL</b>		<b>SPECIFICATION</b>		<b>PROCUREMENT</b>	
.XXX ± 0.003"	1°	APPROVAL	INITIALS	DATE	12900 Alondra Blvd. Cerritos, CA 90703		
		DRAWN BY	K.LE	07/22/25	TITLE		
		CHECKED BY	XXX	XX/XX/XXXX	CONNECTOR, 38999III/24 13-35		
		TEST ENG	XXX	XX/XX/XXXX	PIN/S.C., PT FILTER "N" PLZN		
		QUALITY	XXX	XX/XX/XXXX	SCALE	SUB-DIRECTORY/	
		DESIGN ENG	XXX	XX/XX/XXXX	3:1	XXXXX	
		MFG ENG	XXX	XX/XX/XXXX	SIZE	CAGE CODE	
		ECO APPRV	XXX	XX/XX/XXXX	C	30990	
					DRAWING NO.	OL_J993JSCN35CPAN	
					SHEET	1	OF 1
					REV.	x1	

4

3

2

1