

4

3

2

1

REVISIONS			
REV.	DESCRIPTION	DATE	APPROVED
X1	OL	07/14/25	P. WALKER

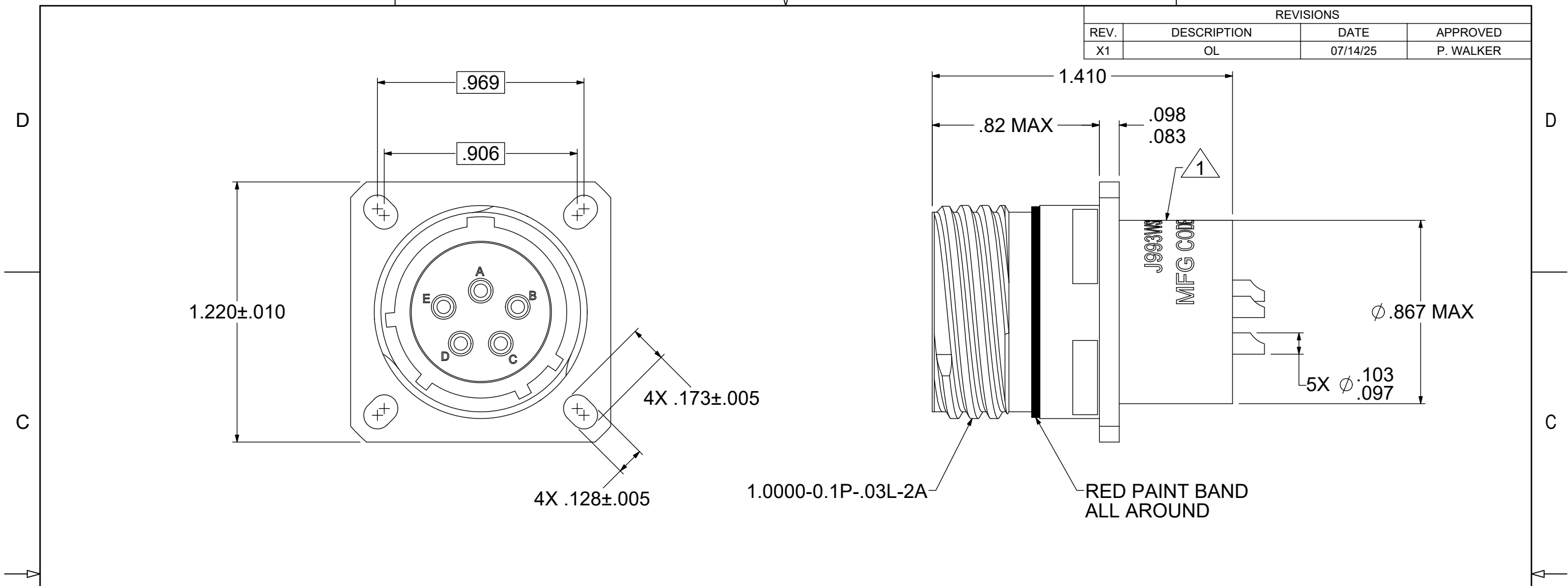

MATERIAL AND FINISH:	ELECTRICALS:	MECHANICAL:	ENVIRONMENTAL:
SHELL: ALUMINUM ALLOY PER ASTM-B211 OR ASTM-B221. FINISH: OLIVE DRAB CADMIUM PLATE.  CONTACT: COPPER ALLOY PER SAE-AS39029, FINISH: GOLD PLATED.  CAPACITORS: CERAMIC, PLANAR.  INSULATORS: EPOXY GLASS LAMINATE PER MIL-DTL-38999.  INTERFACIAL SEAL: FLUOROSILICONE PER MIL-DTL-38999.  GROUND SPRING: BERYLLIUM COPPER, SILVER PLATED.  FERRITE: NICKEL ZINC.  SOLDER PREFORMS: INDIUM SOLDER ALLOY, 50Pb/50In.  POTTING: EPOXY 2850FT/CAT 9.	<b>CM-FILTER</b> A. CAPACITANCE: 4,000-6,000 pF. B. I.R.: 5,000 MΩ MIN AT 500 VDC C. D.W.V: 500 VDC 2 SECONDS MIN. D. ATTENUATION: PER MIL-STD-220 AT 25 °C 2 dB MIN. AT 5 MHz 8 dB MIN. AT 10 MHz 30 dB MIN. AT 100 MHz 43 dB MIN. AT 500-1000 MHz	ALL INTERFACE DIMENSIONS PER MIL-DTL-38999.  INSERT ARRANGEMENT 15-5 PER MIL-STD-1560 PIN ENGAGEMENT.  MARKING: MARK WITH "J993WSD05GPAN" MFG CODE DATE CODE IN LOCATION SHOWN	TEMPERATURE RANGE: -55 C TO +125 C  ENVIRONMENTAL TESTING PER MIL-DTL-38999 AVAILABLE UPON REQUEST.

<b>NOTES:</b> 1. THESE CHARACTERISTICS ARE TYPICAL AND FOR REFERENCE. 2. FOR QUESTIONS PLEASE CONTACT SALES@AMPHENOLCDI.COM	DIMENSIONS ARE IN INCHES ± TOLERANCES UNLESS OTHERWISE NOTED		MATERIAL		SPECIFICATION		PROCUREMENT	
	.XX ± 0.005" ANGULAR .XXX ± 0.003" 1"		APPROVAL	INITIALS	DATE	<b>Amphenol</b> 12900 Alondra Blvd. Cerritos, CA 90703		
	DRAWN BY P. WALKER 07/14/2025		CHECKED BY XXX	TEST ENG XXX	QUALITY XXX	TITLE CONN., 38999/20 15-5 PIN/SC C-FLTR "N" PLZN		
	NEXT ASSY. USED ON		DESIGN ENG XXX	MFG ENG XXX	ECO APPRV XXX	SCALE 3:1	SUB-DIRECTORY/ XXXXX	SHEET 1 OF 1
THE INFORMATION CONTAINED HEREIN IS PROPRIETARY TO AMPHENOL AND SHALL IN NO WAY BE REPRODUCED OR DISCLOSED IN WHOLE OR IN PART OR USED FOR ANY DESIGN OR MANUFACTURE EXCEPT WHEN SUCH USER POSSESSES DIRECT, WRITTEN AUTHORIZATION FROM AMPHENOL.		APPLICATION THIRD ANGLE PROJECTION		SIZE C	CAGE CODE 30990	DRAWING NO. OL_J993WSBO35APAN	REV. X1	