

FREQUENCY	RETURN LOSS (dB Max.)	INSERTION LOSS (dB/Ft Max.)
DC TO 14 GHz	-17	-2.2
14 TO 20 GHz	-14	-3.0

REVISION HISTORY				
ECO	REV.	DESCRIPTION	DRAWN BY	DATE
205736	A	INITIAL RELEASE	HTRAN	04.12.26

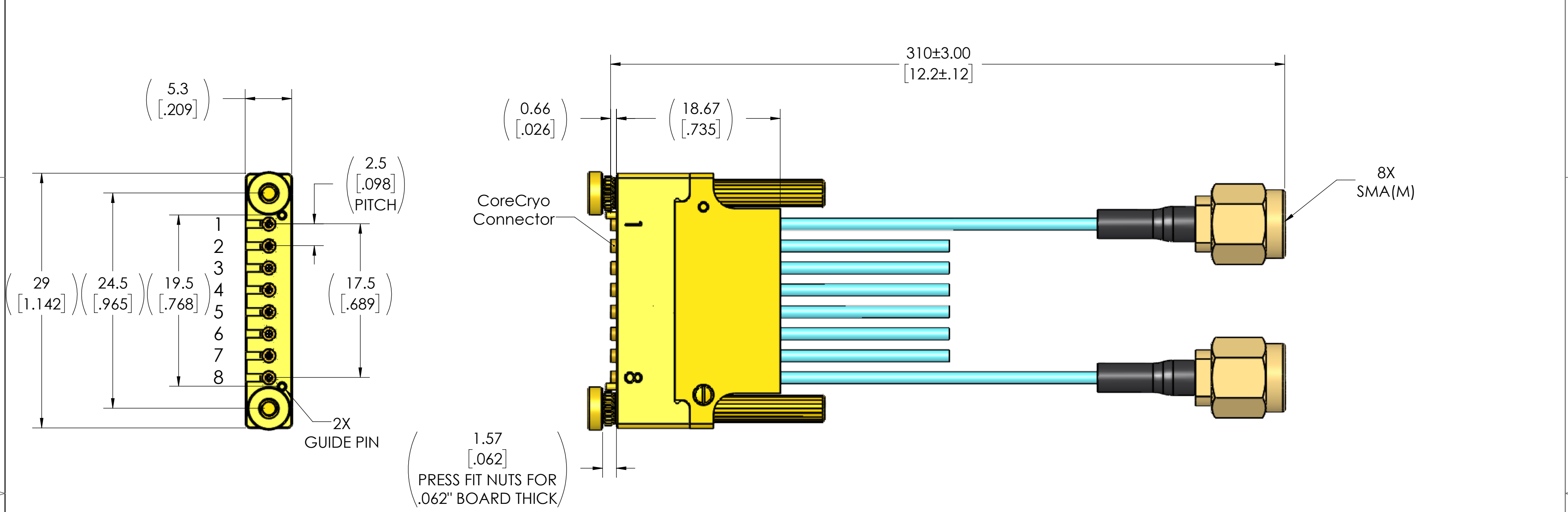

MATERIAL(S):
CoreHC2 connector: (Non-Magnetic)
 Contact, Front Shell, Rear Shell, Ground Slider & Solder Sleeve:
 BeCu Alloy, Gold over Copper Plating
 Spring:
 Stainless Steel SUS130M, Passivate
 Front Insulator:
 Rexolite 1422, PTFE, Peek
 Spring pin:
 Barrel: Phosphor Bronze, Gold over Copper Plating
 Plunger: BeCu Alloy, Gold over Copper Plating
 Spring: NAS 604PH, Gold over Copper Plating
 Tail Needle: BeCu Alloy, Gold over Copper Plating
Precision connector: (Non-Magnetic)
 (Refer to Specification ACDI TM14-0338-00)
HC2 Compliant Carrier: (Non-Magnetic)
 Carrier, Clamp Shell, Dowel Pin, Screw & Press Nut:
 BeCu Alloy, Gold over Copper Plating
 Cable Support: Silicone

Cable: (Non-Magnetic)
 Conductor: Solid Silver Plated Copper Alloy
 Dielectric: Solid PTFE
 Shielding: Helically wrapped flat silver plated copper tape
 Shielding: Silver Plated Copper Alloy
 Jacket: FEP

ELECTRICAL(S):
 Impedance: 50 Ohms Nominal
 Frequency Range: DC to 20 GHz
 VSWR: See Table
 Insertion Loss: See Table
 Working Voltage: 170 Vrms max @ Sea Level
 DWV: 325 Vrms max @ Sea Level
 Insulation Resistance: 5000 MegOhms min
 Spring Pin:
 Current: 1A Max.
 Contact Resistance: 100mOhm Max.
 Phase Matched: +/-2pS (PAIR)

MECHANICAL(S):
 Mating Characteristics:
 SMA Interface per MIL-STD 348
 CoreHC2 Interface per Amphenol CDI
 Force to Engage:
 CoreHC2 (Individual): .85 Lbs Typ.
 SMA: 2in-lbs max
 Force to Disengage:
 CoreHC2 (Individual): .N/A
 SMA: 2in-lbs max
 Connector Durability:
 CoreHC2: 1,000 Cycles
 SMA: 500 Cycles
 Permeability: Less than 1.05 mu.

ENVIROMENTAL(S):
 Temperature Range: -65°C to +125°C
 Thermal Shock:
 MIL-STD-202, Method 107, Test Condition B
 Moisture Resistance:
 MIL-STD-202, Method 106, Insulation resistance at least 200 MegaOhms within 5 minutes after removal from humidity.
 Vibration:
 MIL-STD-202, Method 204, Test Condition D
 Shock:
 MIL-STD-202, Method 213, Test Condition I

DIMENSIONS ARE IN MILLIMETERS [INCHES] ± TOLERANCES UNLESS OTHERWISE NOTED				MATERIAL		SPECIFICATION		PROCUREMENT	
X ± 0.3mm [.012"] XX ± 0.15mm [.006"] XXX ± 0.050mm [.002"] XXXX ± 0.010mm [.0004"] ANGLE ± 0.5°				APPROVAL	INITIALS	DATE	Amphenol		12900 Alondra Blvd. Cerritos, CA 90703
	DRAWN BY	HT	04.12.26	TITLE		CoreCryo 047 NM Assy, 1xRow HC STRIPLINE 8CH to SMA(M)			
	CHECKED BY			SCALE		3:1 SUB-DIRECTORY/			
	TEST ENG			APPLICATION		OUTLINE SHEET 1 OF 1			
	QUALITY			DESIGN ENG	HT	04.12.26	SIZE	CAGE CODE	DRAWING NO.
	MFG ENG			ECO APPRV	SEE ECO	04.12.26	C	30990	TM4CSSS28R2MS031C
									REV. A

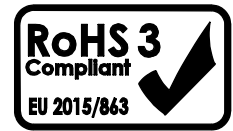

THE INFORMATION CONTAINED HEREIN IS PROPRIETARY TO AMPHENOL AND SHALL IN NO WAY BE REPRODUCED OR DISCLOSED IN WHOLE OR IN PART OR USED FOR ANY DESIGN OR MANUFACTURE EXCEPT WHEN SUCH USER POSSESSES DIRECT, WRITTEN AUTHORIZATION FROM AMPHENOL.